

AVERY DENNISON MARKETING SPECIFICATION

© 2019 AVERY DENNISON CORPORATION. ALL RIGHTS RESERVED

HISTORY

REV.	DATE	DESCRIPTION
A	07.31.19	RELEASED
B	09.10.19	MAX BUNDLE WAS CORRECTED TO BE 38.1mm

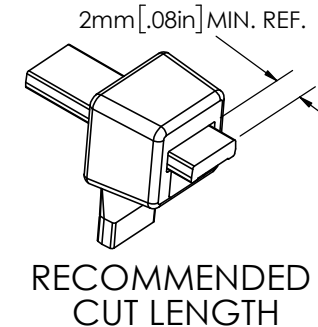
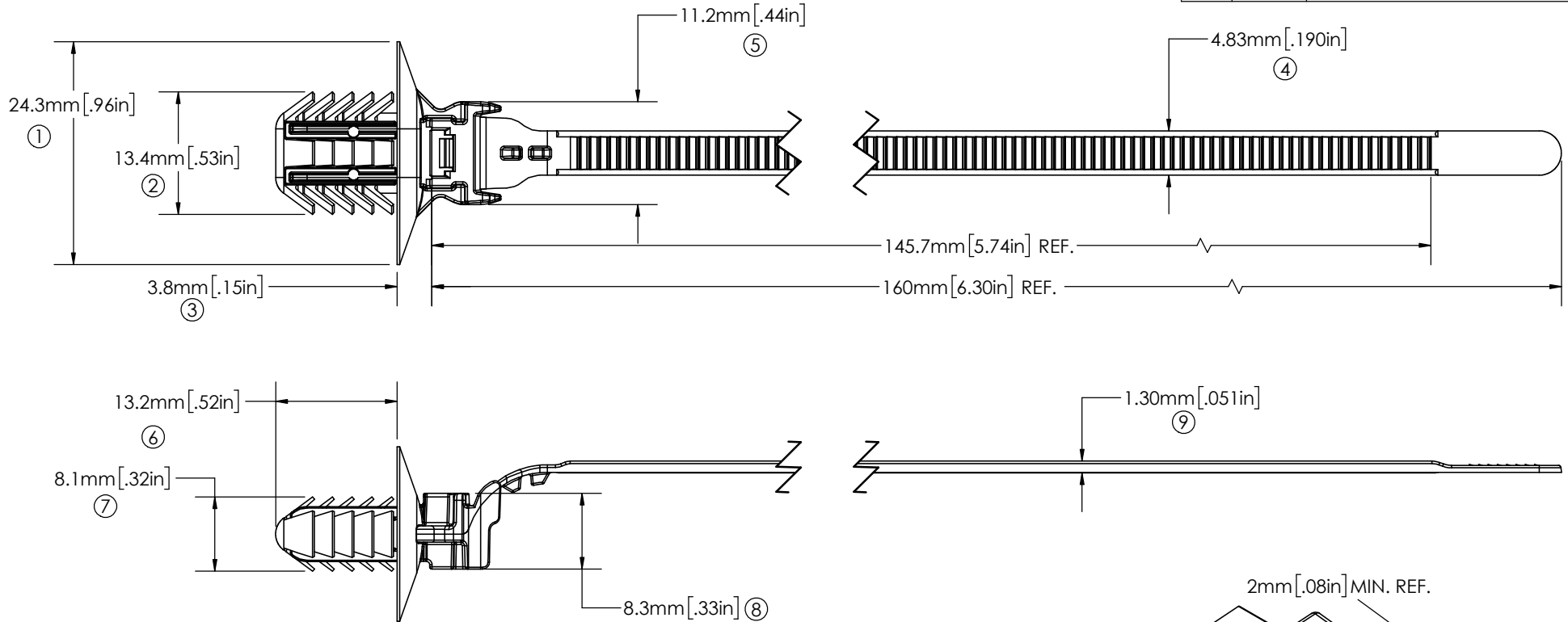

10	△	FLAMMABILITY:	HB RATED PER FMVSS302
11	△	TENSILE STRENGTH:	50 lbf / 222N MIN.
		MOUNTING:	OVAL SIZES: 6.2mm X 12.2mm; 6.5mm X 12.5mm 6.5mm X 13.0mm; 7.0mm X 12.0mm THICKNESS: 0.6mm TO 7.0mm
		INSERTION:	10lbf / 44.5N MAX
		EXTRACTION:	25lbf MIN. per USCAR-44 NOM. FORCES: >40lbf / 177.9N
		OPERATING TEMP RANGE:	-40 °F (-40 °C) TO 239 °F (115 °C) CONTINUOUS AND 257 °F (125 °C) AT MAXIMUM EXPOSURE
		WEIGHT:	2.1g
		BUNDLE DIAMETER:	Ø 1.6mm TO Ø 38.1mm
		TOOL:	12001 - HAND TOOL 12500 - PNEUMATIC TOOL
		TOOL TENSION SETTING:	6 - 8
		PACKAGING:	1000/BAG, 5 BAGS/MASTER

NOTES:
1. △ = INDICATES SPECIAL CHARACTERISTIC

APPROVALS:	ENG. APPR. <i>Daniel Gilbertson</i>	09.10.19
	Q.A. APPR. <i>Caitlin Vaillancourt</i>	09.10.19

SPECIFIED TOLERANCES ARE:
 .XX ± .03 INCHES .X ± .7 mm
 .XXX ± .010 INCHES .XX ± .25 mm
 ANGULAR: ± 2°

MATERIAL
NYLON 6/6, HEAT STABILIZED
 COLOR
BLACK



DESCRIPTION
OVAL FIR TREE TIE
 STOCK NO. **20196-0**
 REV. **B**